

# USER MANUAL



# UNITY LASERS

**RAW** 1.7 (DMX+ILDA)  
**RAW** 3 (DMX+ILDA)  
**RAW** 5 (DMX+ILDA)  
**RAW** 10 (DMX+ILDA)

<p>Notice AVOID EYE OR SKIN EXPOSURE TO DIRECT OR SCATTERED LIGHT CLASS 4 LASER PRODUCT</p>	<p><b>Manufactured / Certified by</b> <b>Unity Lasers s.r.o.</b> Odboraska, 23 831 02 Bratislava Slovakia, Europe <b>UNITY Laser LLC</b> 1265 Upsala Road, Suite 1165, Sanford, FL 32771</p>	<p>Classified per IEC 60825-1: 2014 Complies with US FDA CDHR laser safety standards 21 CFR 1040.10 &amp; 1040.11 and Laser notice</p>
---	--	--

# CONTENTS

INTRODUCTION	3
WHAT IS INCLUDED	3
UNPACKING INSTRUCTIONS	3
GENERAL INFORMATION	3
SAFETY NOTES	4
LASER AND SAFETY NOTES	5
LASER EMISSION DATA	6
LASER COMPLIANCE STATEMENT	6
PRODUCT SAFETY LABEL LOCATION	7
PRODUCT SAFETY LABELS	9
INTERLOCK CONNECTION DIAGRAM	11
INSTRUCTIONS FOR USING E-STOP SYSTEM	12
THEORY OF OPERATION	13
PROPER USAGE	13
RIGGING	13
OPERATION	14
• CONNECTING THE LASER SYSTEM	14
• TURNING OFF THE LASER SYSTEM	14
• HOW TO USE THE LCD SCREEN	15
• LCD MENU FUNCTIONS	16
• DMX NORMAL MODE CHANNEL INSTRUCTIONS	17
• DMX EXPERT MODE CHANNEL INSTRUCTIONS	18
SAFETY TESTS	20
• E-STOP FUNCTION	20
• INTERLOCK RESET FUNCTION (POWER)	20
• KEY SWITCH FUNCTION	20
• INTERLOCK RESET FUNCTION (REMOTE INTERLOCK BYPASS)	20
MODEL SPECIFICATION	21
• PRODUCT SPECIFICATION (RAW 1.7)	21
• FRONT & REAR PANEL VIEW (RAW 1.7)	22
• DIMENSION DETAILS (RAW 1.7)	23
• PRODUCT SPECIFICATION (RAW 3)	24
• FRONT & REAR PANEL VIEW (RAW 3)	25
• DIMENSION DETAILS (RAW)	26
• PRODUCT SPECIFICATION (RAW 5)	27
• FRONT & REAR PANEL VIEW (RAW 5)	28
• DIMENSION DETAILS (RAW 5)	29
• PRODUCT SPECIFICATION (RAW 10)	30
• FRONT & REAR PANEL VIEW (RAW 10)	31
• DIMENSION DETAILS (RAW 10)	32
ILDA PINOUT SPECIFICATION	33
TECHNICAL INFORMATION – MAINTENANCE	34
SERVICE	34

## INTRODUCTION

Thank you for purchasing this purchase. To optimize the performance of your laser, please read these operating instructions carefully and familiarize yourself with the basic operations of this system. These instructions contain important safety information regarding the use and maintenance of this system as well. Please keep this manual with the unit, for future reference. If you sell this product to another user, be sure that they also receive this document.

## NOTICE

- We are constantly striving to improve the quality of our products. As such, the content of this manual may be changed without notice.
- We have tried our best to guarantee the accuracy of this manual. If you have any questions or find any errors, please contact us directly to help address this.

## WHAT IS INCLUDED

Name	Pcs.	Notes
Raw 1.7/3/5/10 laser w/ integrated DMX and ILDA control option	1	
Estop safety box	1	
Estop cable (10M / 30FT)	1	
ILDA cable (10M / 30ft)	1	
Power cable (1.5M / 4.5ft)	1	
Interlock	1	
Keys	4	
Manual	1	
Quickstart guide	1	
Variance card	1	
Carton packaing	1	

## UNPACKING INSTRUCTIONS

- Open the package and carefully unpack everything inside.
- Ensure all parts are present and in good condition.
- Do not use any equipment that appears to be damaged.
- If any parts are missing or damaged then please immediately notify your carrier or local distributor.

## GENERAL INFORMATION

The following chapters explain important information about lasers in general, basic laser safety and some tips about how to use this device correctly. Please read this information as it contains critical information you must be aware of, prior to using this system.

## SAFETY NOTES

**WARNING! This projector is Class 4 laser product. It must never be used for audience-scanning applications. The output beam of the projector must always be at least 3 metres above the floor in the audience. See the Operating Instructions section for further information.**

**Please read the following notes carefully! They include important safety information about the installation, usage, and maintenance of this product.**

- Keep this user manual for future consultation. If you sell this product to another user, be sure that they also receive this document.
- Always make sure that the voltage of the outlet to which you are connecting this product is within the range stated on the decal or rear panel of the product.
- This product is not designed for use outdoors in adverse weather conditions. To prevent risk of fire or shock, do not expose this product to rain or moisture.
- Always disconnect this product from the power source before cleaning it or replacing the fuse.
- Make sure to replace the fuse with another of the same type and rating.
- If mounting is overhead, always secure this product to a fastening device using a safety chain or a cable.
- In the event of a serious operating problem, stop using the projector immediately. Never try to repair the unit except in a controlled environment under trained supervision. Repairs carried out by unskilled people can lead to damage or malfunction of the unit, as well as exposure to dangerous laser light.
- Never connect this product to a dimmer pack.
- Make sure the power cord is not crimped or damaged.
- Never disconnect the power cord by pulling or tugging on the cord.
- Never carry a product from the power cord or any moving part. Always use the hanging/mounting bracket or the handles.
- Always avoid eye or skin exposure to direct or scattered light from this product.
- Lasers can be hazardous and have unique safety considerations. Permanent eye injury and blindness is possible if lasers are used incorrectly. Pay close attention to each safety REMARK and WARNING statement in this user manual. Read all instructions carefully BEFORE operating this device.
- Never intentionally expose yourself or others to direct laser light.
- This laser product can potentially cause instant eye injury or blindness if laser light directly strikes the eyes.
- It is illegal and dangerous to shine this laser into audience areas, where the audience or the other personnel could get direct laser beams or bright reflections into their eyes.
- It is a US Federal offense to shine any laser at aircraft.
- **No service allowed by customer. There are no user serviceable parts inside the unit. Do not attempt any repairs yourself.**
- **Service is only to be handled by the factory or authorized factory trained technicians. Product is not to be modified by the customer.**
- **Caution** – use of controls or adjustments or performance of procedures other than those specified herein may result in hazardous radiation exposure.

## LASER AND SAFETY NOTES

### STOP AND READ ALL THE LASER SAFETY NOTES BELOW

Laser Light is different from any other light sources with which you may be familiar. The light from this product can cause eye and skin injury if not set up and used properly. Laser light is thousands of times more concentrated than light from any other kind of light source. This concentration of light can cause instant eye injuries, primarily by burning the retina (the light sensitive portion at the back of the eye). Even if you cannot feel “heat” from laser beam, it can still potentially injure or blind you or your audience. Even very small amounts of laser light are potentially hazardous even at long distances. Laser eye injuries can happen quicker than you can blink. It is incorrect to think that because these laser entertainment products use high speed scanned laser beams, that an individual laser beam is safe for eye exposure. It is also incorrect to assume that because the laser light is moving, it is safe. This is not true.

Since eye injuries can occur instantly, it is critical to prevent the possibility of any direct eye exposure. It is not legal to aim this laser projector into areas where people can be exposed. This is true even if it is aimed below people’s faces, such as on a dance floor.

- Do not operate the laser without first reading and understanding all safety and technical data in this manual.
- Always set up and install all laser effects so that all laser light is at least 3 metres (9.8 feet) above the floor on which people can stand. See the “Proper Usage” section later in this manual.
- After set up, and prior to public use, test the laser to ensure proper function. Do not use if any defect is detected.
- Laser Light - Avoid Eye or Skin Exposure to Direct or Scattered Light.
- Do not point lasers at people or animals.
- Never look into the laser aperture or laser beams.
- Do not point lasers in areas where people can potentially be exposed, such as uncontrolled balconies, etc.
- Do not point lasers at highly reflective surfaces, such as windows, mirrors and shiny metal objects. Even laser reflections can be hazardous.
- Never point a laser at aircraft, as this is a US Federal Offense.
- Never point un-terminated laser beams into the sky.
- Do not expose the output optic (aperture) to cleaning chemicals.
- Do not use the laser if the housing is damaged, open, or if the optics appear damaged in any way.
- Never leave this device running unattended.
- In the United States, this laser product may not be purchased, sold, rented, leased or loaned for use unless the recipient possesses a valid Class 4 laser light show variance from the US FDA CDRH.
- This product must always be operated by a skilled and well-trained operator who is familiar with the valid Class 4 laser light show variance from the CDRH as stated above.
- The legal requirements for using laser entertainment products vary from country to country. The user is responsible for the legal requirements at the location/country of use.
- Always use appropriate lightning safety cables when hanging this projector overhead.

## LASER EMISSION DATA

- **Class 4 Laser Projector - Avoid Eye and Skin Exposure to Direct or Scattered Light!**
- **This Laser Product is designated as Class 4 during all procedures of operation.**
- Further guidelines and safety programs for safe use of lasers can be found in the ANSI Z136.1 Standard "For Safe Use of Lasers", available from the Laser Institute of America: [www.laserinstitute.org](http://www.laserinstitute.org). Many local governments, corporations, agencies, military and others, require all lasers to be used under the guidelines of ANSI Z136.1.

## UNITY Lasers s.r.o.

- Laser Classification Class 4
- Red Laser Medium AlGaInP, 638 nm, depending on model
- Green Laser Medium InGaN, 520-525 nm, depending on model
- Blue Laser Medium InGaN, 445 nm to 465 nm depending on model
- Beam Diameter <5 mm at aperture
- Divergence (each beam) <1.1 mrad
- Maximum total output power 1,7 – 10W depending on model

## LASER COMPLIANCE STATEMENT

- This laser product complies with FDA performance standards for laser products except for deviations pursuant to Laser Notice No. 56, dated May 8, 2019. This laser device is classified as a Class 4 demonstration laser product.
- No maintenance is required to keep this product in compliance with laser performance standards.

## PRODUCT SAFETY LABEL LOCATION

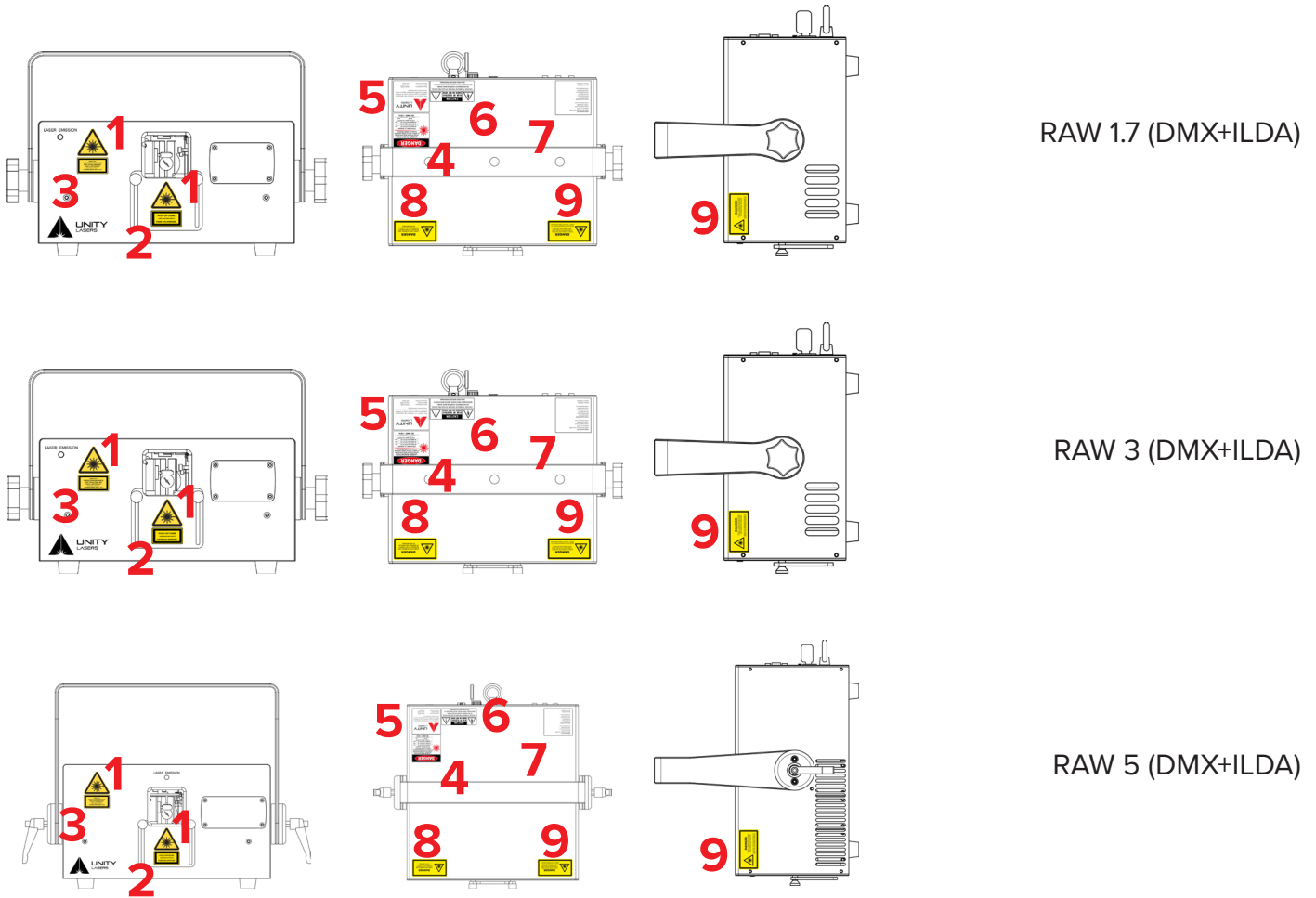

### FRONT PANEL

1. Hazard Warning Symbol
2. Aperture Label
3. Laser Light Warning Label

### TOP PANEL

4. Danger Label
5. Certification Label
6. Danger Warning Label
7. Manufacturer Label
8. Aircraft Warning Label
9. Interlock Label

See next page for large reproductions of the product labels. All these labels must be intact and legible prior to using the projector.

## PRODUCT SAFETY LABEL LOCATION [CONTINUED]

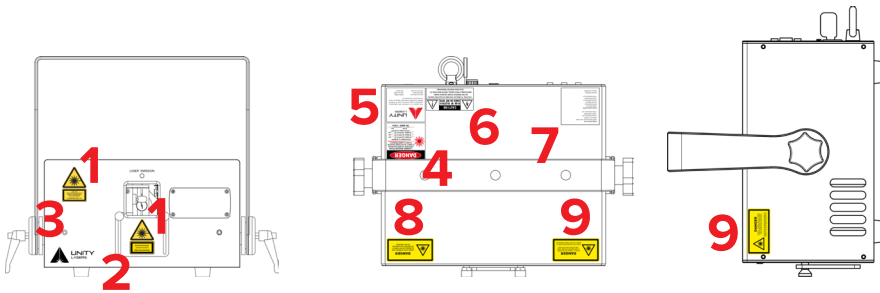

RAW 10 (DMX+ILDA)

### FRONT PANEL

1. Hazard Warning Symbol
2. Exposure Label
3. Laser Light Warning Label

### TOP PANEL

4. Danger Label
5. Certification Label
6. Danger Warning Label
7. Manufacturer Label
8. Aircraft Warning Label
9. Interlock Label

See next page for large reproductions of the product labels. All these labels must be intact and legible prior to using the projector.



## PRODUCT SAFETY LABELS



Logotype Danger Label



Hazard Warning Symbol



Aperture Label



Aircraft Warning Label



Interlocked Housing Label



Laser Light Warning Label

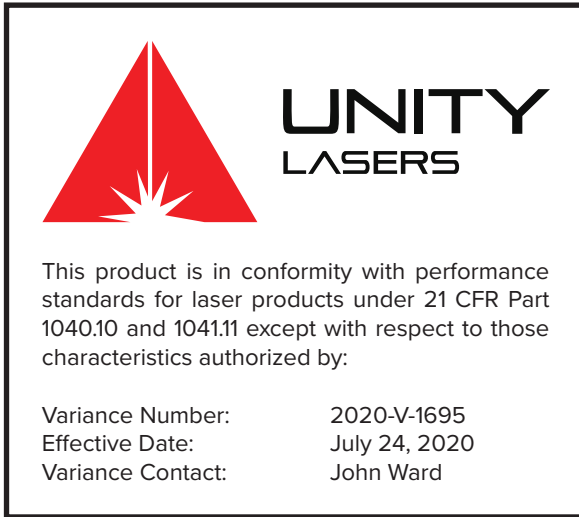

Certification Label



Manufacturer Label

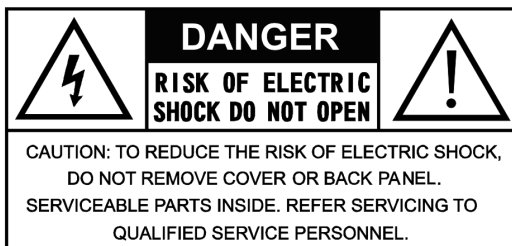

Danger Warning Label

## INTERLOCK CONNECTION DIAGRAM

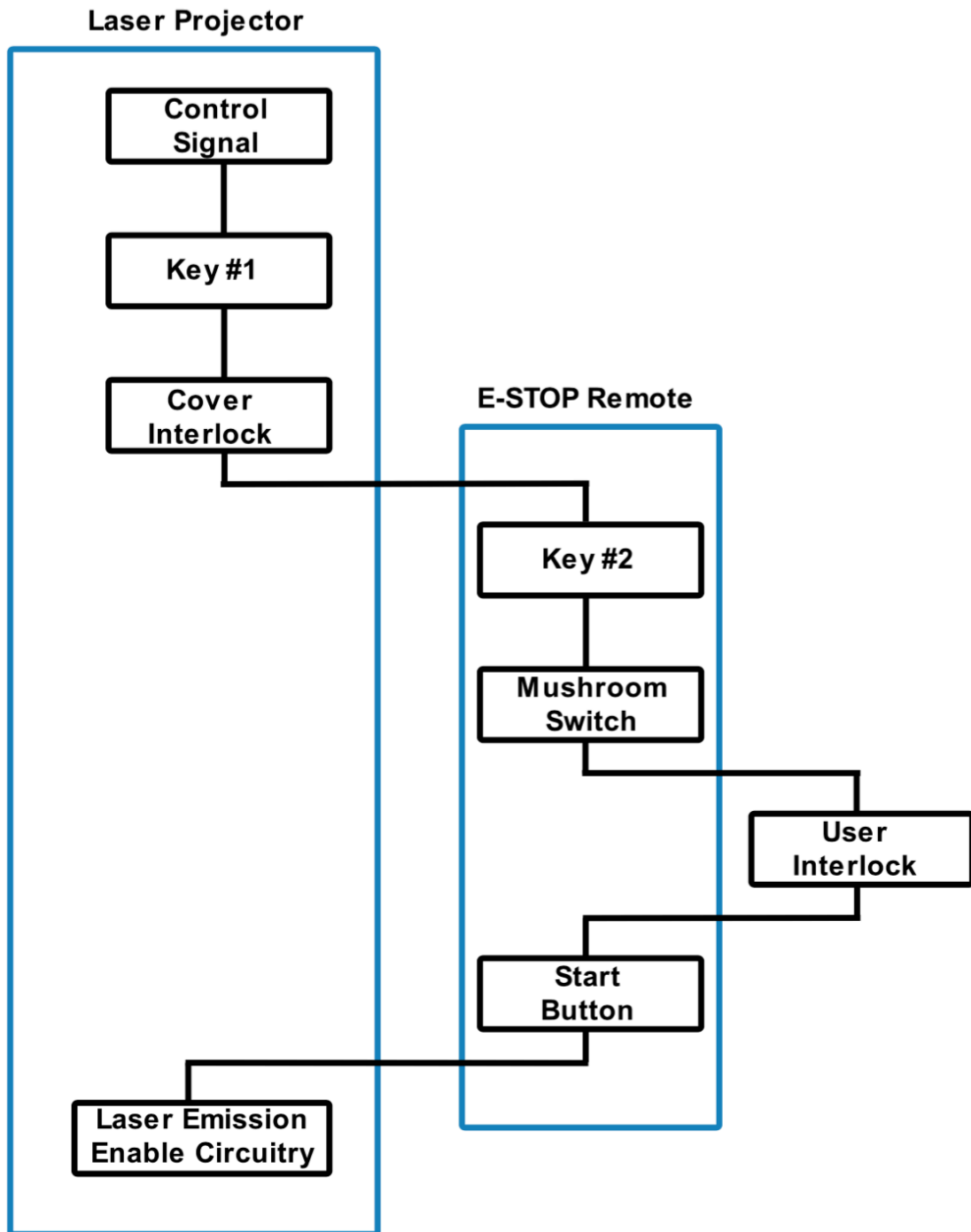

## INSTRUCTIONS FOR USING E-STOP SYSTEM

Connect the E-stop box to the 3-pin interlock connector on the rear of the laser projector using a 3-PIN XLR cable.

\*\* Note that the E-stop box has an available secondary interlock port. The secondary port is to be used to interface a secondary interlock device (e.x. door switch or pressure sensitive step pad). If a secondary interlock device is NOT used then the secondary port must have the bypass shunt plug inserted.



The diagram below outlines the pinout configuration for the 3-pin connection from E-STOP box to the rear of the projector.

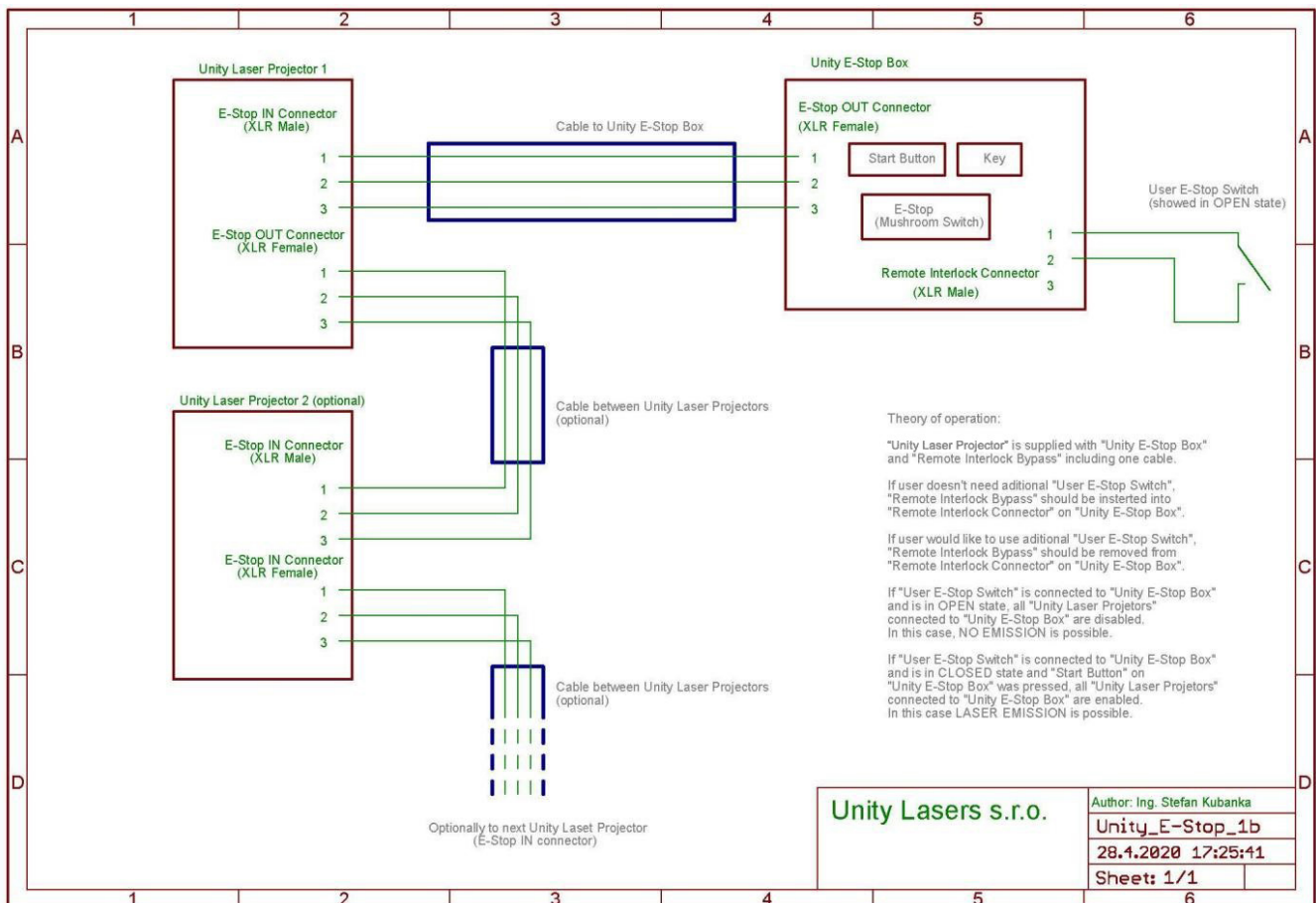

## THEORY OF OPERATION

“UNITY Laser projector” is supplied with “E-Stop Box” and “Remote Interlock Bypass” including one cable. If user doesn’t need additional “User E-Stop Switch”, “Remote Interlock Bypass” should be inserted into “Remote Interlock Connector” on “E-Stop Box”. If the user would like to use additional “User E-Stop Switch”, “Remote Interlock Bypass” should be removed from “User E-Stop Connector” on “E-Stop Box”. If the “User E-Stop Switch” is used, then laser emission is ONLY possible, when it is in CLOSED state, and also all other safety features are satisfied (e.g. mushroom switch, keyswitches, scanfail safety, ...)

## PROPER USAGE

This product is for overhead mounting only. For safety purposes, this projector should be mounted on steady elevated platforms or sturdy overhead supports using suitable hanging clamps. In all cases, you must use safety cables. International laser safety regulations require that the laser products must be operated in the fashion illustrated below, with a minimum of 3 metres (9.8 ft.) of vertical separation between the floor and the lowest laser light vertically. Additionally, 2.5 metres of horizontal separation is required between laser light and the audience or other public spaces. The audience area can be passively protected by sliding the aperture cover plate upwards and fixing it in proper position by the two thumb screws.

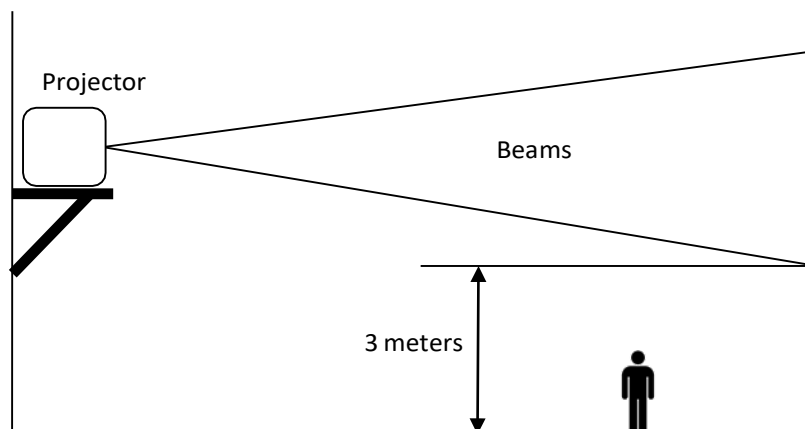

## RIGGING

- Be sure that the structure onto which you are mounting this product can support its weight.
- Mount the product securely. You can do this with a screw, a nut, and a bolt. You may also use a mounting clamp if rigging this product onto a truss. The U-shaped support bracket has three mounting holes which may be used to secure the clamps to the projector.
- When mounting this product overhead, always use a safety cable.
- Always consider ease of access to the unit before deciding on a location for this product.

**Caution** – use of controls or adjustments or performance of procedures other than those specified herein may result in hazardous radiation exposure.

This Laser Product is designated as Class 4 during all procedures of operation.

**REMINDER:** In the United States, this laser product may not be purchased, sold, rented, leased or loaned for use unless the recipient possesses a valid Class 4 laser light show variance from the US FDA CDRH.

## **OPERATION**

### **CONNECTING THE LASER SYSTEM**

1. To control the system with an external signal such as Ethernet or ILDA, plug the corresponding cable into its designated connector at the back of the unit.
2. Connect the Emergency STOP remote to the socket labeled as a “Remote Input” with the supplied 3-pin XLR cable.
3. Insert the Remote Interlock Bypass to the E-STOP Remote to disable the interlock (USA only).
4. Use supplied Neutrik powerCON power cable to connect the laser system to a main power supply using the input connector.

### **INSERT THE SAFETY KEYS**

1. Turn the laser system key to the on position.
2. Turn the E-STOP remote key to the on position.

### **DISABLE THE INTERLOCK**

1. Release the E-STOP button by pulling upwards.
2. Press the START button on the E-STOP remote.

### **TURNING OFF THE LASER SYSTEM**

1. Turn off the key switch; Deactivate via the red mushroom switch on the E-stop box. You can remove the 3-pin Interlock too, if the laser will be kept for no use. (We recommend having a professional operator to keep the keys and 3-pin Interlock switch.)
2. Turn off the power to the projector via the power switch.

## OPERATION [CONTINUED]

### HOW TO USE THE LCD SCREEN



The green LED next to the LCD display will flash in specific pattern to indicate what mode you are currently in.

Mode	Speed
DMX and Slave mode	Flashing at a medium speed
Auto mode	Flashing at at slow speed
Music mode	Always on or flashing with a rhythm
ILDA mode	Flashing at a fast speed

See next page for the LCD functions and menus.

## OPERATION [CONTINUED]

### LCD MENU FUNCTIONS

First Menu	Second Menu	Third Menu
<b>Function Mode</b>	DMX 512 Mode Auto Mode Sound Active Mode	
<b>Show Listing</b>	Choose List All Lists	Play a show list
<b>Playing Show</b>	Choose Show All the shows/001-255	Play a specific show in the selected list
<b>Play Setup</b>	Play speed ----- Play mode	Select play speed for the show (default is 50%) Loop play Random play
<b>Address Setup</b>	Address Setup 001	Set the DMX address
<b>Channel Setup</b>	Normal Mode Expert Mode	10 channels for Normal mode 34 channels for Expert mode
<b>Laser Setup</b>	Scanner speed ----- ----- Color ----- ----- ----- ----- Laser modulation	Can be set up to 40kpps. Set correct speeds to scanner specifications. Single RGY RBP GBC RGB (default setting) WYPC Analog TTL
<b>General Setup</b>	Reset Default Master Setup Back Light (Back Light continued) Display Setup (Change LCD Display) About System	Yes/No Turn on/Turn Off Normally ON Delay 155 Off Rotate 180deg Normal Display



## OPERATION [CONTINUED]

### DMX NORMAL MODE CHANNEL INSTRUCTIONS (10 CHANNEL MODE)

Channel	Type	Value	Function
CH1	ON/OFF	0 1-255	Laser off Laser on (brightness from 1% to 100%)
CH2	Strobe	1-255	Strobe speed, from slow to fast
CH3	Pattern Size	0-255	Select pattern size
CH4	X-Axis Position	0-255	Change X position, value 128 is the middle position (valid only when CH3 is selected 1-255)
CH5	Y-Axis Position	0-255	Change Y position, value 128 is the middle position (valid only when CH3 is selected 1-255)
CH6	Choose show	0-255	Select a show for every 2 values (CH9 selected a show list)
CH7	Color	0-63 64-95 96-127 128-159  160-191 192-233 224-255	Select single color Fixed color/color changing effect speed selection Color changing effect speed selection Color changing effect speed selection/flowing color effect speed selection Flowing color effect speed selection Flowing color effect speed selection Color drawing effect speed selection
CH8	Line Scanning Dot Scanning	0-127 128-255	Scan speed selection Scan speed selection
CH9	Show List	0-255	Select a show list every 8 values (value 0 selcts all lists)
CH10	Auto Mode Music Mode	0-26 27-127 128-255	Default running speed of Auto Mode Select running speed (from slow to fast) Select Mic sensitivity for Music Mode (from high to low)

## OPERATION [CONTINUED]

### DMX EXPERT MODE CHANNEL INSTRUCTIONS (CH1-CH17)

Channel	Type	Value	Function
CH1	ON/OFF	0 1-255	Laser off Laser on (brightness from 1% to 100%)
CH2	Strobe	1-255	Strobe speed, from slow to fast
CH3	Pattern size	0-255	Select pattern size
CH4	X-Axis position	0-255	Change X position, value 128 is the middle position (valid only when CH3 is selected 1-255)
CH5	Y-Axis position	0-255	Change Y position, value 128 is the middle position (valid only when CH3 is selected 1-255)
CH6	Choose show	0-255	Select a show for every 2 values (CH9 selected a show list)
CH7	Color	0-63 64-95 96-127 128-159  160-191 192-233 224-255	Select single color Fixed color/color changing effect speed selection Color changing effect speed selection Color changing effect speed selection/flowing color effect speed selection Flowing color effect speed selection Flowing color effect speed selection Color drawing effect speed selection
CH8	Line scanning Dot scanning	0-127 128-255	Scan speed selection Scan speed selection
CH9	Show list	0-255	Select a show list every 8 values (value 0 selcts all lists)
CH10	Auto mode Music mode	0-26 27-127 128-255	Default running speed of Auto mode Select running speed (from slow to fast) Select Mic sensitivity for Music mode (from high to low)
CH11	Z-rotation	1-127 128-255	Select rotation angle Select rotation speed
CH12	X-rotation	1-127 128-255	Select rotation angle Select rotation speed
CH13	Y-rotation	1-127 128-255	Select rotation angle Select rotation speed
CH14	X-moving	1-127 128-255	Select moving positon Select moving speed
CH15	Y-moving	1-127 128-255	Select moving positon Select moving speed
CH16	Zooming	1-127 128-255	Select zooming size Select zooming speed
CH17	Drawing	1-255	Select drawing speed

## OPERATION [CONTINUED]

### DMX EXPERT MODE CHANNEL INSTRUCTIONS CH18-CH34

Channel	Type	Value	Function
CH18	X-wave Y-wave	1-127 128-255	Select X waving speed Select Y waving speed
CH19	Strobe	1-255	Strobe speed, from slow to fast
CH20	Pattern size	0-255	Select pattern size
CH21	X-axis position	0-255	Change X-position, value 128 is the middle position. (valid only when CH3 is selected 1-255)
CH22	Y-axis position	0-255	Change X-position, value 128 is the middle position. (valid only when CH3 is selected 1-255)
CH23	Choose show	0-255	Select a show for every 2 values (CH26 selected a show list)
CH24	Color	0-63 64-95 96-127 128-159  160-191 192-233 224-255	Select single color Fixed color/color changing effect speed selection Color changing effect speed selection Color changing effect speed selection/flowing color effect speed selection Flowing color effect speed selection Flowing color effect speed selection Color drawing effect speed selection
CH25	Line scanning Dot scanning	0-127 128-255	Scan speed selection Scan speed selection
CH26	Show list	0-255	Select a show list every 8 values (value 0 selects all lists)
CH27	Z-rotation	1-127 128-255	Select rotation angle Select rotation speed
CH28	X-rotation	1-127 128-255	Select rotation angle Select rotaiton speed
CH29	Y-rotation	1-127 128-255	Select rotation angle Select rotaiton speed
CH30	X-moving	1-127 128-255	Select moving position Select moving speed
CH31	Y-moving	1-127 128-255	Select moving position Select moving speed
CH32	Zooming	1-127 128-255	Select zooming size Select zooming speed
CH33	Drawing	1-255	Select drawing speed
CH34	X-wave Y-wave	1-127 128-255	Select X waving speed Select Y waving speed

## SAFETY TESTS

### E-STOP FUNCTION

- With the projector operating and projecting laser light, press the red E-stop switch. The projector must shut off immediately.
- Twist the red E-stop button clockwise, until the button resets to the up position and the green “Ready” LED illuminates. The projector must not emit any laser light.
- Press the start button on E-stop box. The projector should now re-start and begin emitting laser light \*with a small delay (USA only)
- Verify that the emission indicator is now lit.

### INTERLOCK RESET FUNCTION (POWER)

- With the projector operating and projecting laser light, unplug the AC power cable. The projector must shut off immediately.
- Plug the power cable back in. The projector must not emit any laser light.
- Press the start button on the E-stop box. The projector should now re-start and begin emitting laser light.
- Verify that the emission indicator is now lit.

### KEY SWITCH FUNCTION

- With the projector operating and projecting laser light, turn the key switch on the remote E-stop control unit to off. The projector must shut off immediately.
- Turn the key switch back to on. The projector must not emit any laser light.
- Press the start button on the E-stop box. The projector should now re-start and begin emitting laser light.
- Verify that the emission indicator is now lit.

### INTERLOCK RESET FUNCTION (REMOTE INTERLOCK BYPASS)

- With the projector operating and projecting laser light, remove Remote Interlock Bypass. The projector must shut off immediately.
- Plug the Remote Interlock Bypass back in. The projector must not emit any laser light.
- Press the start button on the E-stop box. The projector should now re-start and begin emitting laser light.
- Verify that the emission indicator is now lit.

**If any of the above tests fail, the projector must be taken out of service and returned to the manufacturer for repair.**

## PRODUCT SPECIFICATION (RAW 1.7 DMX+ILDA)

<b>Product Name:</b>	Unity RAW 1.7 (DMX+ILDA)
<b>Type Of Laser:</b>	Full-colour, Semiconductor diode laser system
<b>Guaranteed Optical Output:</b>	>1.7W
<b>Suitable For:</b>	Clubs, DJs, smaller indoor venues, home and hobby use. Beam show, text, graphic, and mapping capable
<b>Control Signal:</b>	DMX mode, sound active mode, and ILDA mode (we recommend Pangolin FB3QS and QuickShow for ILDA control)
<b>Scanning System:</b>	30,000 points per second @ 8°
<b>Scan Angle:</b>	45°
<b>Safety:</b>	Fully complies with the latest EN 60825-1 and FDA regulations
<b>Weight:</b>	5.3kg
<b>Package Includes:</b>	Laser projector, Estop box, Estop cable (10M/30ft), ILDA cable (10M/30ft), power cable (1.5M/4.5ft), interlock, keys, manual, quickstart guide, variance card, carton packaging (* service dongle if outside US)
<b>R   G   B [mW]:</b>	350   500   1,000
<b>R   G   B [Wavelength]:</b>	638nm   520nm   450nm
<b>Beam Size [mm]:</b>	5 x 3
<b>Beam Divergence:</b>	<1.1mrad [Full Angle]
<b>Modulation:</b>	Analog 50kHz
<b>Power Requirements:</b>	100-230V/50Hz
<b>Consumption:</b>	Max. 100W
<b>Operation Temperature:</b>	10-40 °C
<b>Ingress Rating:</b>	IP4X
<b>System Features:</b>	Adjustments for color channels (R,G,B), size/position/invert (X,Y), DMX in/out, ILDA in/out, Estop in/out, power in/out, sound active mode, digital display for DMX address and settings
<b>Laser Safety Features:</b>	Keyed interlock, Emission delay, Magnetic interlock, Scan-fail safety, Mechanical shutter, Adjustable aperture masking plate
<b>Notice:</b>	*Due to Advanced Optical Correction technology used in our laser systems, each laser colour's optical power output may slightly differ from the specification of the respective laser module(s) installed. This does not affect the total guaranteed power output
<b>Dimensions [mm]:</b>	Depth: 238 Width: 192 Height: 126

## FRONT & REAR PANEL VIEW (RAW 1.7 DMX+ILDA)

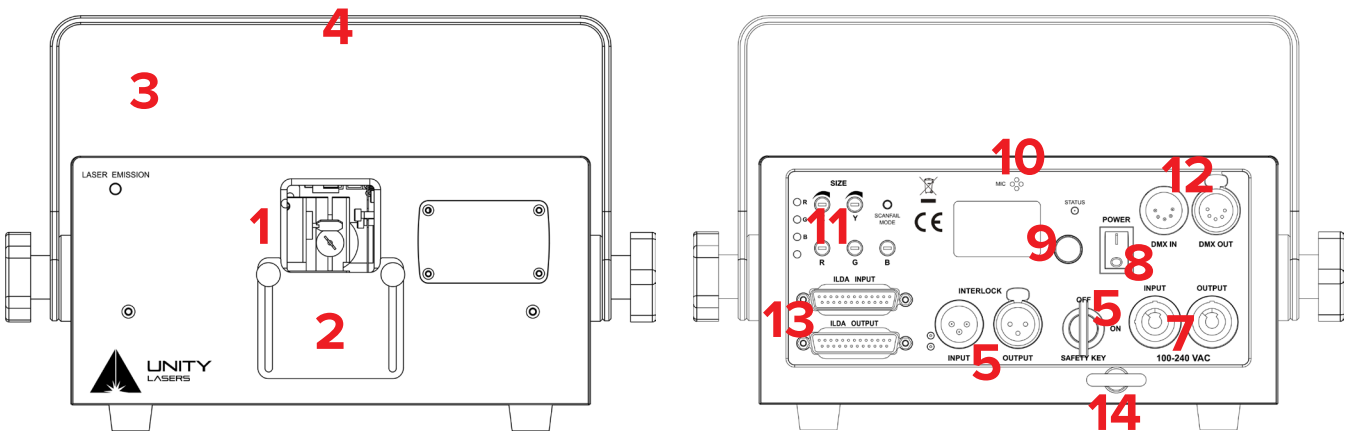

NO.	Name	Function
1.	Laser Aperture	Laser output, do not look directly into this aperture.
2.	Aperture Masking Plate	Can be moved up and down when two locking bolts are loosened.
3.	Laser Emission	When this Indicator is lit up the laser system is ready to emit the laser radiation as soon as It receives Instructions from control software.
4.	Attachment bracket	The attachment bracket spins 360 degrees around the laser body whilst it can be locked in desired position by two small locking handles on sides.
5.	3-Pin Interlock	Laser output is available only when the Interlock is connected. It could be used to connect a laser emergency switch.
6.	Key Switch	Turn the key switch ON to allow laser output.
7.	Power In & Out	AC 100-240V power Input and output sockets. With output feature you can connect the device to one another using the Input and output sockets. They must be the same fixtures. DO NOT mix fixtures.
8.	Power ON & OFF	Power On/Off
9.	LCD Display	LCD display with function setting knob
10.	Microphone	Built in Microphone used for
11.	Function Knob	For X/Y moving, rotation Y, Invert & Size; RGB and brightness adjustment.
12.	DMX IN & OUT	Use these ports to connect DMX control signal or to daisy chain the DMX signal between multiple laser display systems.
13.	DB25 In & Out	DB25 Interface In and Out for ILDA Mode
14.	Safety Eyelet	Use this together with appropriate safety wire to secure the system against unexpected fall.

## DIMENSION DETAILS (RAW 1.7 DMX+ILDA)

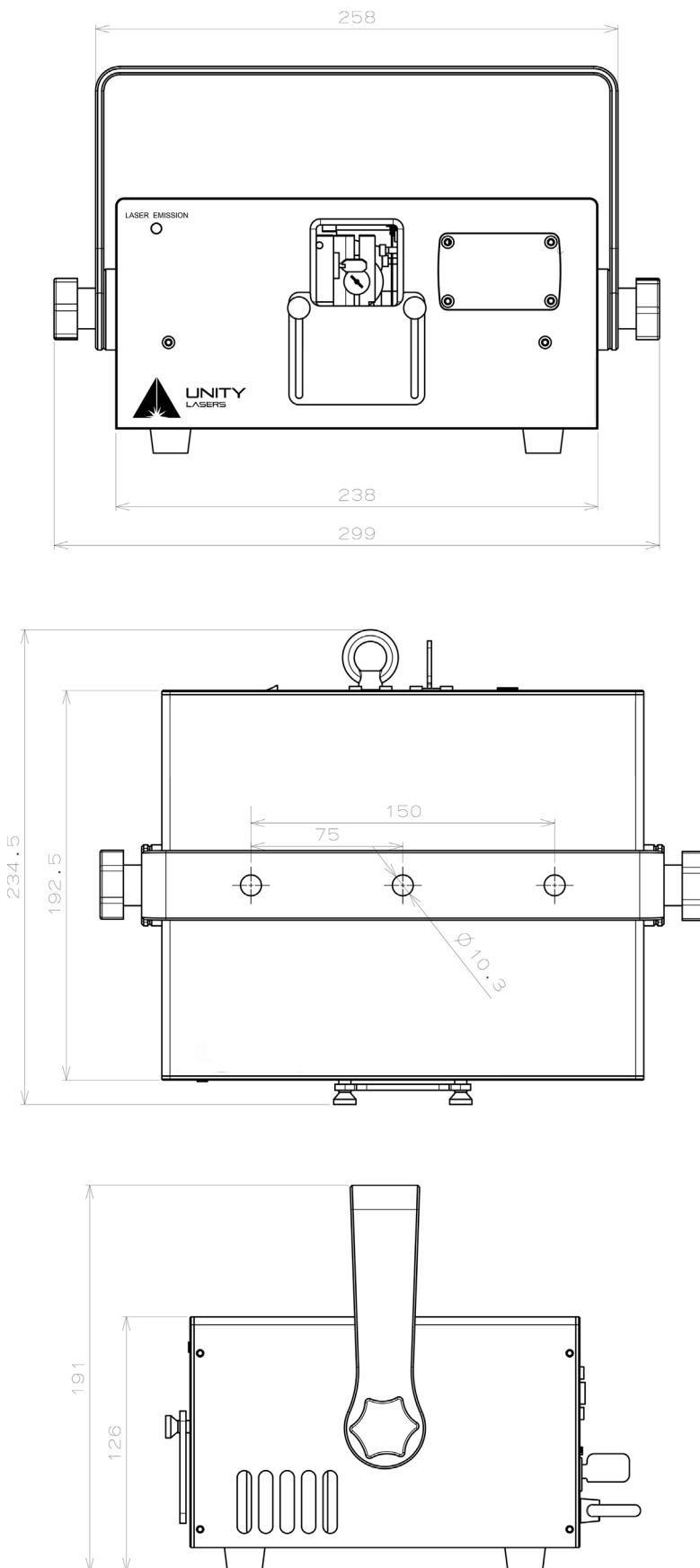

## PRODUCT SPECIFICATION (RAW 3 DMX+ILDA)

<b>Product Name:</b>	RAW 3 (DMX+ILDA)
<b>Type Of Laser:</b>	Full-colour, Semiconductor diode laser system
<b>Guaranteed Optical Output:</b>	>3W
<b>Suitable For:</b>	Clubs, DJs, medium indoor venues (up to 3,000 people), home and hobby use. Beam show, text, graphic, and mapping capable
<b>Control Signal:</b>	DMX mode, sound active mode, and ILDA mode (we recommend Pangolin FB3QS and QuickShow for ILDA control)
<b>Scanning System:</b>	30,000 points per second @ 8°
<b>Scan Angle:</b>	45°
<b>Safety:</b>	Fully complies with the latest EN 60825-1 and FDA regulations
<b>Weight:</b>	5.3kg
<b>Package Includes:</b>	Laser projector, Estop box, Estop cable (10M/30ft), ILDA cable (10M/30ft), power cable (1.5M/4.5ft), interlock, keys, manual, quickstart guide, variance card, carton packaging (* service dongle if outside US)
<b>R   G   B [mW]:</b>	500   800   1,700
<b>R   G   B [Wavelength]:</b>	638nm   525nm   455nm
<b>Beam Size [mm]:</b>	5 x 3
<b>Beam Divergence:</b>	<1.1mrad [Full Angle]
<b>Modulation:</b>	Analog 50kHz
<b>Power Requirements:</b>	100-230V/50Hz
<b>Consumption:</b>	Max. 100W
<b>Operation Temperature:</b>	10-40 °C
<b>Ingress Rating:</b>	IP4X
<b>System Features:</b>	Adjustments for color channels (R,G,B), size/position/invert (X,Y), DMX in/out, ILDA in/out, Estop in/out, power in/out, sound active mode, digital display for DMX address and settings
<b>Laser Safety Features:</b>	Keyed interlock, Emission delay, Magnetic interlock, Scan-fail safety, Mechanical shutter, Adjustable aperture masking plate
<b>Notice:</b>	*Due to the Advanced Optical Correction technology used in our laser systems, each laser colour's optical power output may slightly differ from the specification of the respective laser module(s) installed. This does not affect the total guaranteed power output
<b>Dimensions [mm]:</b>	Depth: 238 Width: 192 Height: 126



## FRONT & REAR PANEL VIEW (RAW 3 DMX+ILDA)

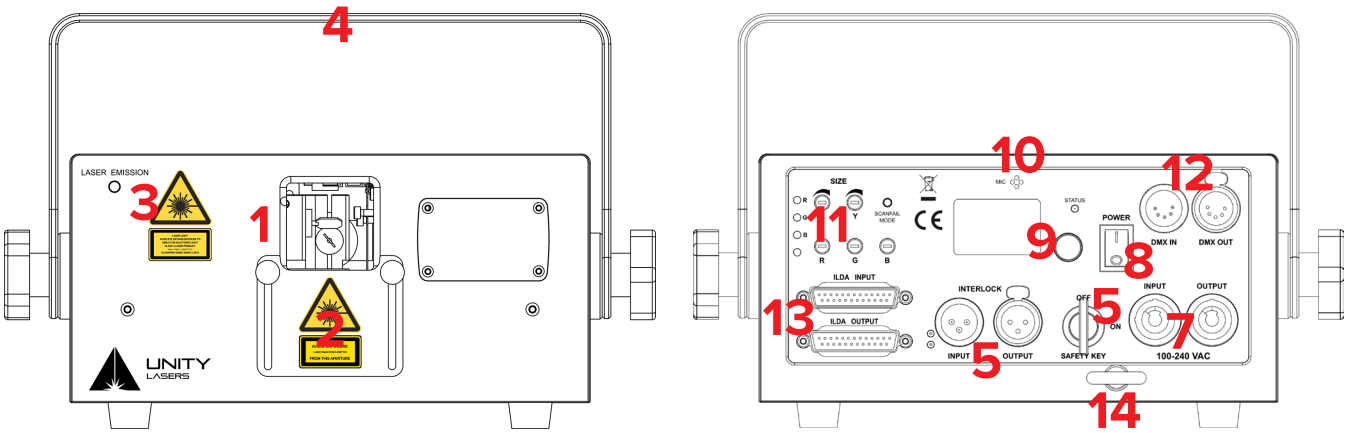

NO.	Name	Function
1.	Laser Aperture	Laser output, do not look directly into this aperture.
2.	Aperture Masking Plate	Can be moved up and down when two locking bolts are loosened.
3.	Laser Emission	When this Indicator is lit up the laser system is ready to emit the laser radiation as soon as It receives Instructions from control software.
4.	Attachment bracket	The attachment bracket spins 360 degrees around the laser body whilst it can be locked in desired position by two small locking handles on sides.
5.	3-Pin Interlock	Laser output Is available only when the Interlock is connected. It could be used to connect a laser emergency switch.
6.	Key Switch	Turn the key switch ON to allow laser output.
7.	Power In & Out	AC 100-240V power Input and output sockets. With output feature you can connect the device to one another using the Input and output sockets. They must be the same fixtures. DO NOT mix fixtures.
8.	Power ON & OFF	Power On/Off
9.	LCD Display	LCD display with function setting knob
10.	Microphone	Built in Microphone used for
11.	Function Knob	For X/Y moving, rotation Y, Invert & Size; RGB and brightness adjustment.
12.	DMX IN & OUT	Use these ports to connect DMX control signal or to daisy chain the DMX signal between multiple laser display systems.
13.	DB25 In & Out	DB25 Interface In and Out for ILDA Mode
14.	Safety Eyelet	Use this together with appropriate safety wire to secure the system against unexpected fall.

## DIMENSION DETAILS (RAW 3 DMX+ILDA)

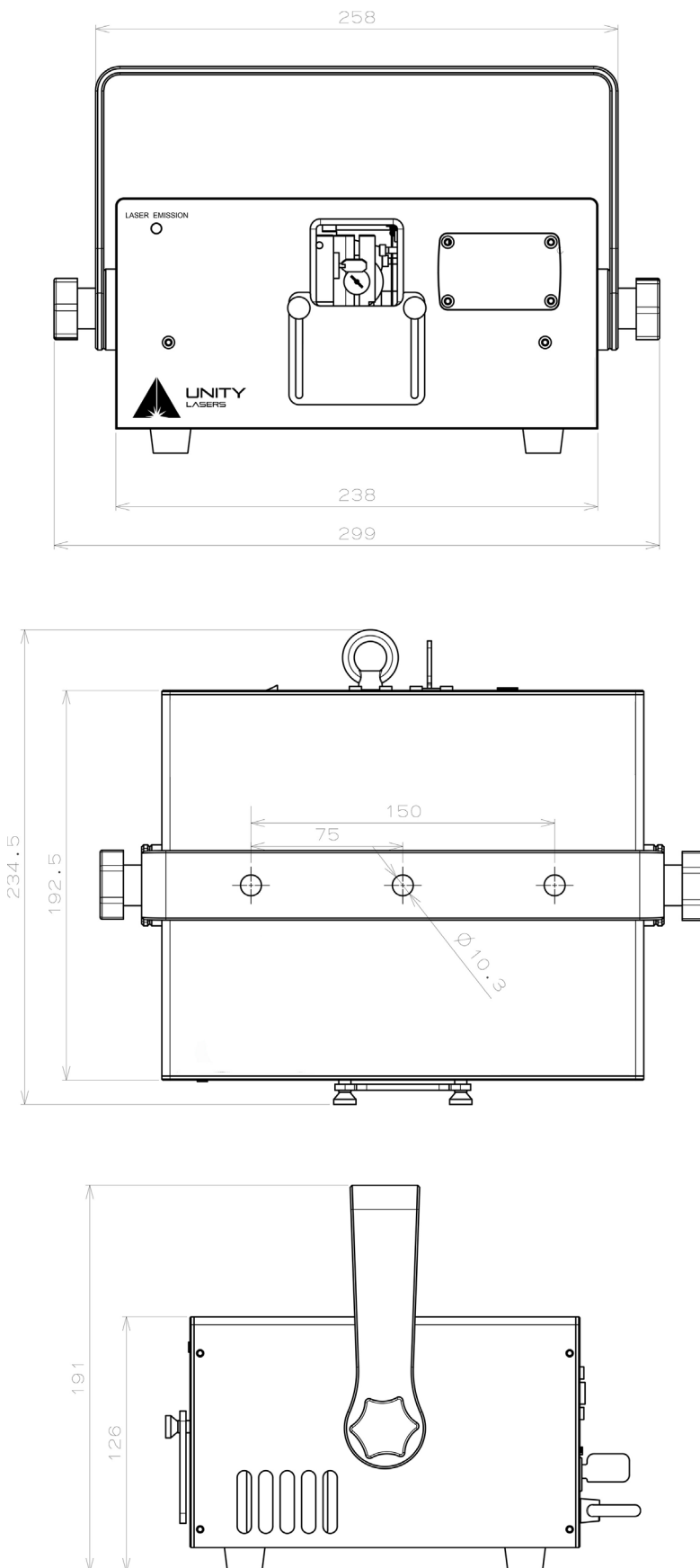

## PRODUCT SPECIFICATION (RAW 5 DMX+ILDA)

<b>Product Name:</b>	RAW 5 (DMX+ILDA)
<b>Type Of Laser:</b>	Full-colour, Semiconductor diode laser system
<b>Guaranteed Optical Output:</b>	>5W
<b>Suitable For:</b>	Clubs, DJs, large indoor venues (up to 5,000 people), small outdoor shows. Beam show, text, graphic, and mapping capable
<b>Control Signal:</b>	DMX mode, sound active mode, and ILDA mode (we recommend Pangolin FB3QS and QuickShow for ILDA control)
<b>Scanning System:</b>	30,000 points per second @ 8°
<b>Scan Angle:</b>	50°
<b>Safety:</b>	Fully complies with the latest EN 60825-1 and FDA regulations
<b>Weight:</b>	8kg
<b>Package Includes:</b>	Laser projector, Estop box, Estop cable (10M/30ft), ILDA cable (10M/30ft), power cable (1.5M/4.5ft), interlock, keys, manual, quickstart guide, variance card, carton packaging (* service dongle if outside US)
<b>R   G   B [mW]:</b>	1,200   1,000   2,800
<b>R   G   B [Wavelength]:</b>	638nm   525nm   455nm
<b>Beam Size [mm]:</b>	5 x 3
<b>Beam Divergence:</b>	<1.1mrad [Full Angle]
<b>Modulation:</b>	Analog 50kHz
<b>Power Requirements:</b>	100-230V/50Hz
<b>Consumption:</b>	Max. 150W
<b>Operation Temperature:</b>	10-40 °C
<b>Ingress Rating:</b>	IP4X
<b>System Features:</b>	Adjustments for color channels (R,G,B), size/position/invert (X,Y), DMX in/out, ILDA in/out, Estop in/out, power in/out, sound active mode, digital display for DMX address and settings
<b>Laser Safety Features:</b>	Keyed interlock, Emission delay, Magnetic interlock, Scan-fail safety, Mechanical shutter, Adjustable aperture masking plate
<b>Notice:</b>	*Due to the Advanced Optical Correction technology used in our laser systems, each laser colour's optical power output may slightly differ from the specification of the respective laser module(s) installed. This does not affect the total guaranteed power output
<b>Dimensions [mm]:</b>	Depth: 252 Width: 247 Height: 148

## FRONT & REAR PANEL VIEW (RAW 5 DMX+ILDA)

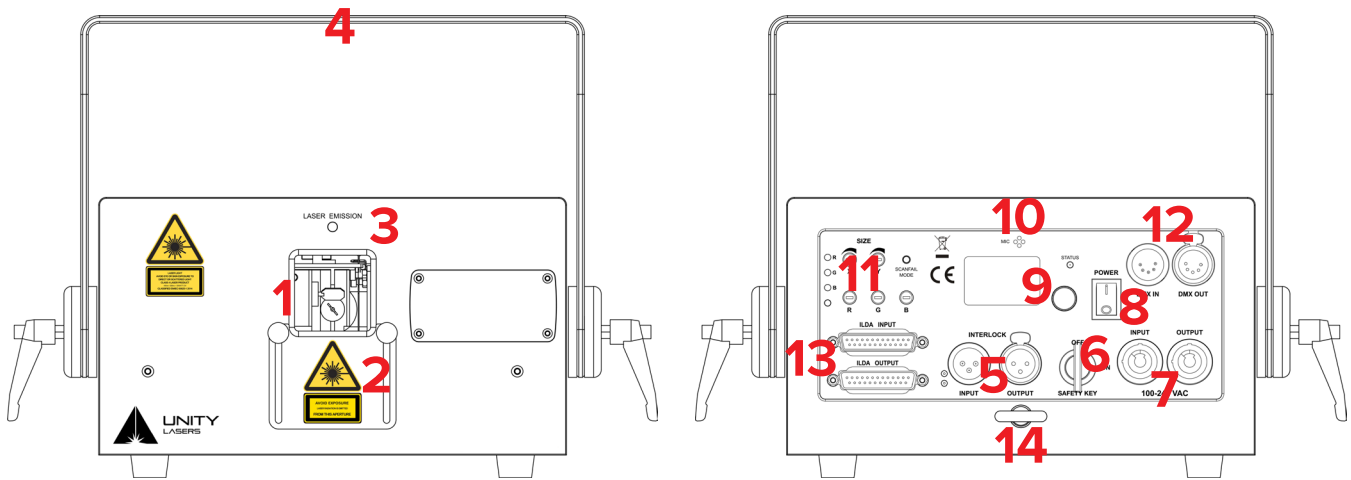

NO.	Name	Function
1.	Laser Aperture	Laser output, do not look directly into this aperture.
2.	Aperture Masking Plate	Can be moved up and down when two locking bolts are loosened.
3.	Laser Emission	When this Indicator is lit up the laser system is ready to emit the laser radiation as soon as it receives instructions from control software.
4.	Attachment bracket	The attachment bracket spins 360 degrees around the laser body whilst it can be locked in desired position by two small locking handles on sides.
5.	3-Pin Interlock	Laser output is available only when the Interlock is connected. It could be used to connect a laser emergency switch.
6.	Key Switch	Turn the key switch ON to allow laser output.
7.	Power In & Out	AC 100-240V power Input and output sockets. With output feature you can connect the device to one another using the Input and output sockets. They must be the same fixtures. DO NOT mix fixtures.
8.	Power ON & OFF	Power On/Off
9.	LCD Display	LCD display with function setting knob
10.	Microphone	Built in Microphone used for
11.	Function Knob	For X/Y moving, rotation Y, Invert & Size; RGB and brightness adjustment.
12.	DMX IN & OUT	Use these ports to connect DMX control signal or to daisy chain the DMX signal between multiple laser display systems.
13.	DB25 In & Out	DB25 Interface In and Out for ILDA Mode
14.	Safety Eyelet	Use this together with appropriate safety wire to secure the system against unexpected fall.

## DIMENSION DETAILS (RAW 5 DMX+ILDA)

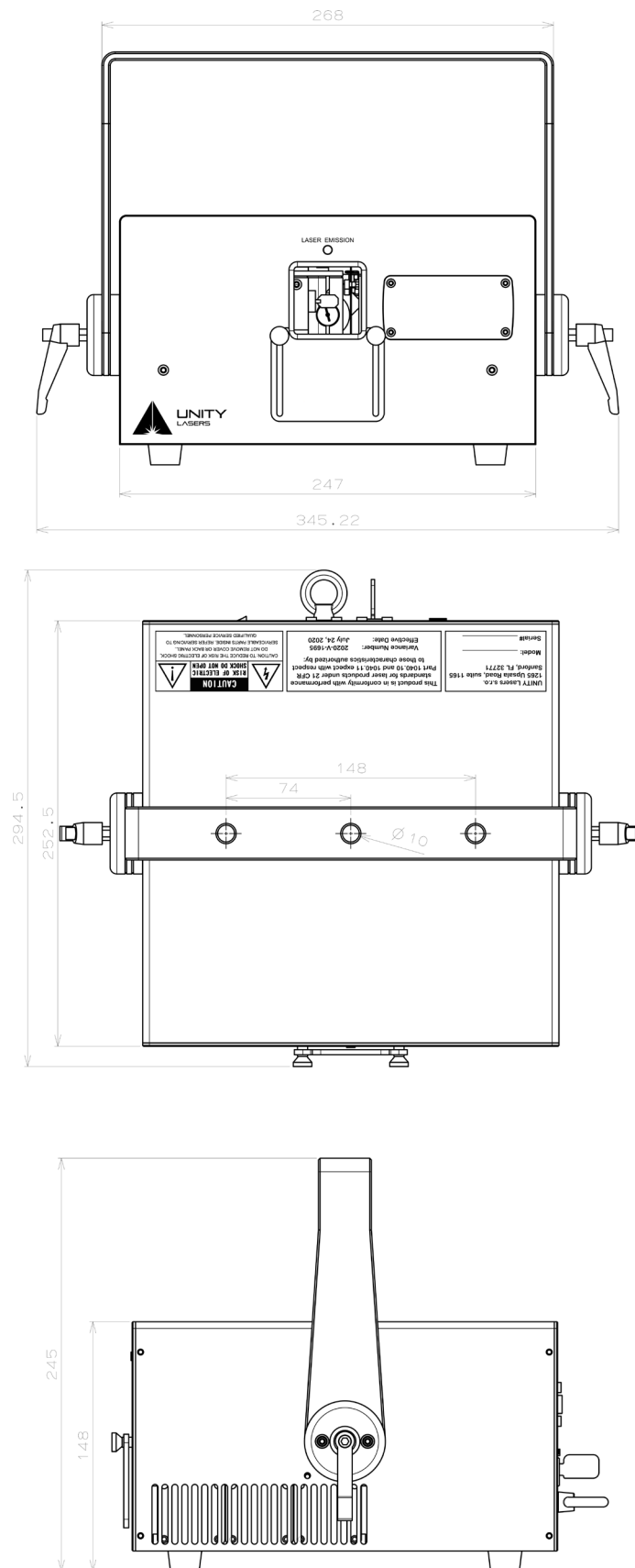

## PRODUCT SPECIFICATION (RAW 10 DMX+ILDA)

<b>Product Name:</b>	Unity RAW 10 (DMX+ILDA)
<b>Type:</b>	full-color, semiconductor diode laser system
<b>Guaranteed optical output:</b>	>10W
<b>Suitable for:</b>	Clubs, DJs, large indoor venues (over 5,000 people), medium sized outdoor shows. Beam show, text, graphic, and mapping capable
<b>Control signal:</b>	DMX mode, sound active mode, and ILDA mode (we recommend Pangolin FB3QS and QuickShow for ILDA control)
<b>Scanning system:</b>	30,000 points per second @ 8°
<b>Safety:</b>	50°
<b>Weight:</b>	12kg
<b>Package includes:</b>	Laser projector, Estop box, Estop cable (10M/30ft), ILDA cable (10M/30ft), power cable (1.5M/4.5ft), interlock, keys, manual, quickstart guide, variance card, carton packaging (* service dongle if outside US)
<b>R   G   B [mW]:</b>	2,700   2,700   4,800
<b>R   G   B [Wavelength]:</b>	638nm   525nm   455nm
<b>Beam size [mm]:</b>	5 x 3
<b>Beam divergence:</b>	<1.1mrad [full angle]
<b>Modulation:</b>	Analog, up to 50kHz
<b>Power requirements:</b>	100-230V/50Hz
<b>Consumption:</b>	max. 350W
<b>Operation temperature:</b>	10-40 °C
<b>Ingress protection rating:</b>	IP4X
<b>System features:</b>	Adjustments for color channels (R,G,B), size/position/invert (X,Y), DMX in/out, ILDA in/out, Estop in/out, power in/out, sound active mode, digital display for DMX address and settings
<b>Laser safety features:</b>	Keyed interlock, emission delay, magnetic interlock, scan-fail safety, mechanical shutter, adjustable aperture masking plate.
<b>Notice:</b>	*Due to Advanced Optical Correction technology used in our laser systems the optical power output of each laser colour within the system may slightly differ from the specification of respective laser module(s) installed. This does not affect the total guaranteed power output.
<b>Dimensions [mm]:</b>	Length: 340 Width: 247 Height: 148

## FRONT & REAR PANEL VIEW (RAW 10 DMX+ILDA)

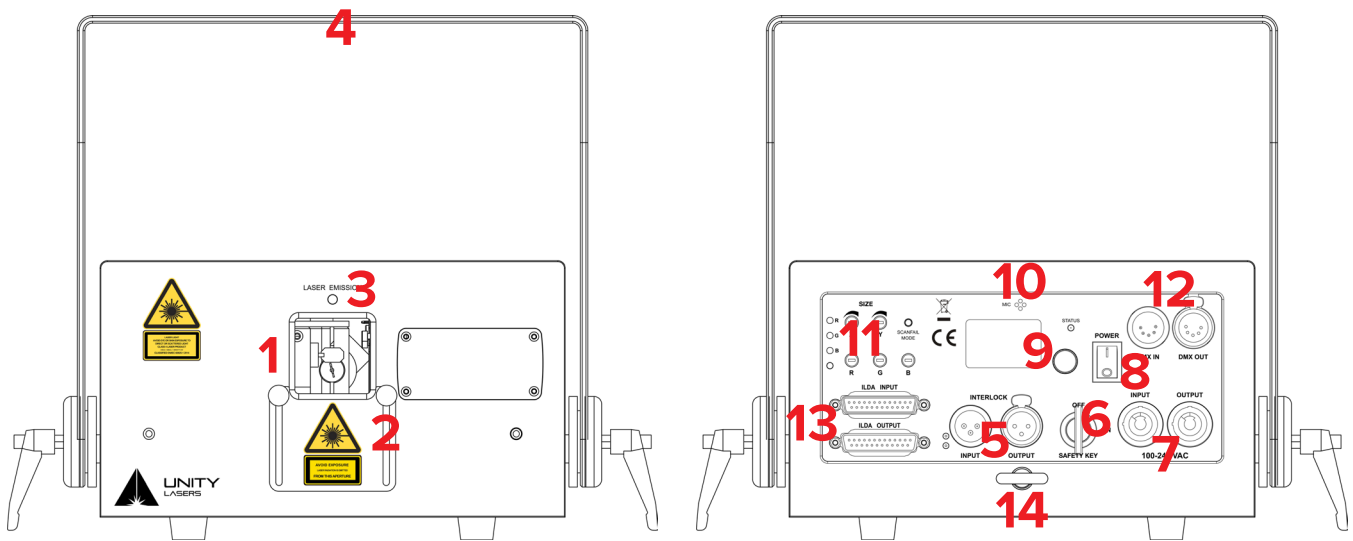

NO.	Name	Function
1.	Laser Aperture	Laser output, do not look directly into this aperture.
2.	Aperture Masking Plate	Can be moved up and down when two locking bolts are loosened.
3.	Laser Emission	When this Indicator is lit up the laser system is ready to emit the laser radiation as soon as It receives Instructions from control software.
4.	Attachment bracket	The attachment bracket spins 360 degrees around the laser body whilst it can be locked in desired position by two small locking handles on sides.
5.	3-Pin Interlock	Laser output is available only when the Interlock is connected. It could be used to connect a laser emergency switch.
6.	Key Switch	Turn the key switch ON to allow laser output.
7.	Power In & Out	AC 100-240V power Input and output sockets. With output feature you can connect the device to one another using the Input and output sockets. They must be the same fixtures. DO NOT mix fixtures.
8.	Power ON & OFF	Power On/Off
9.	LCD Display	LCD display with function setting knob
10.	Microphone	Built in Microphone used for
11.	Function Knob	For X/Y moving, rotation Y, Invert & Size; RGB and brightness adjustment.
12.	DMX IN & OUT	Use these ports to connect DMX control signal or to daisy chain the DMX signal between multiple laser display systems.
13.	DB25 In & Out	DB25 Interface In and Out for ILDA Mode
14.	Safety Eyelet	Use this together with appropriate safety wire to secure the system against unexpected fall.

## DIMENSION DETAILS (RAW 10 DMX+ILDA)

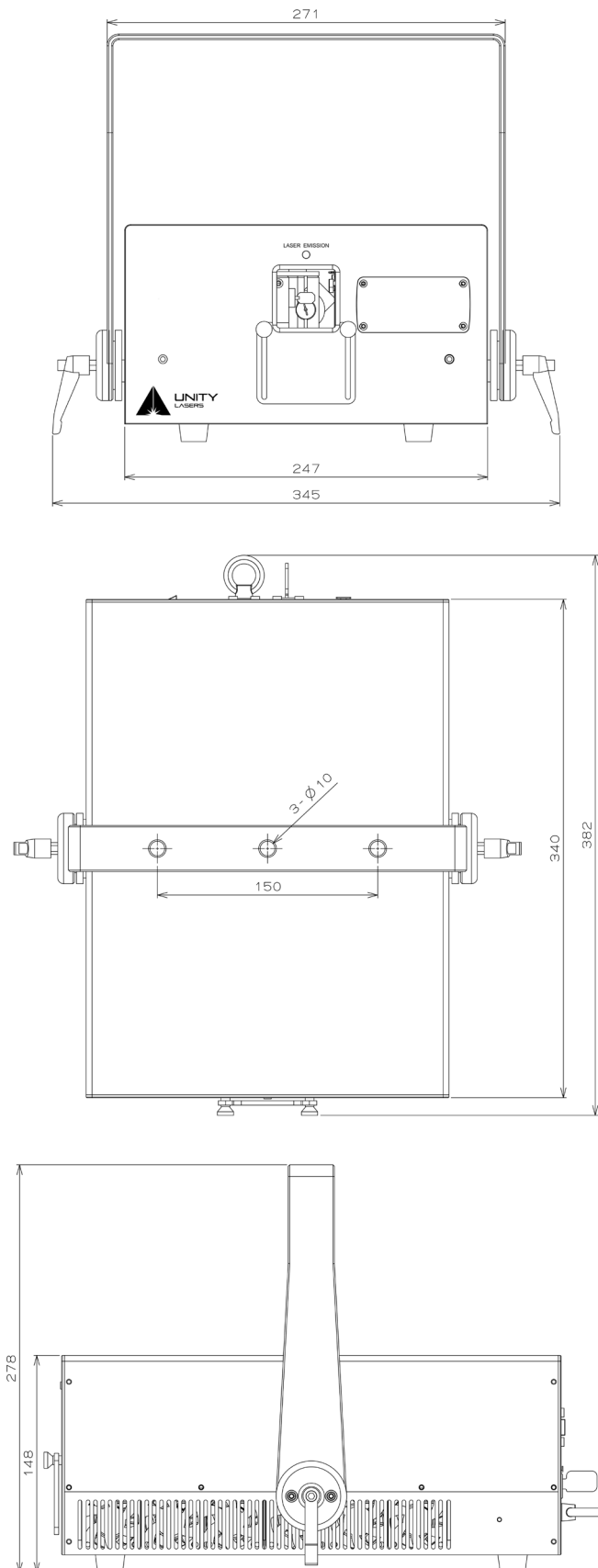



## ILDA PINOUT SPECIFICATION

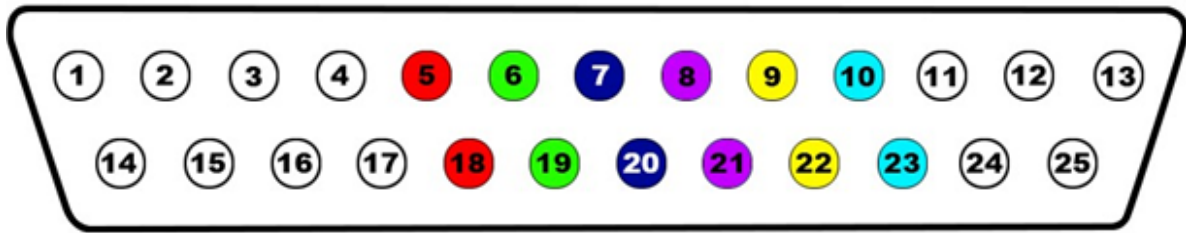

1.	X +	14.	X -
2.	Y +	15.	Y -
3.	Intensity/Blanking +	16.	Intensity/Blanking -
4.	Interlock A	17.	Interlock B
5.	R +	18.	R -
6.	G +	19.	G -
7.	B +	20.	B -
8.	Deep blue +	21.	Deep blue -
9.	Yellow +	22.	Yellow -
10.	Cyan +	23.	Cyan -
11.	Z +	24.	Z -
12.	Not connected	25.	Ground
13.	Shutter		

## TECHNICAL INFORMATION - MAINTENANCE

### GENERAL CLEANING INSTRUCTIONS - TO BE DONE BY USER

Due to fog residue, smoke, and dust cleaning the external body of the projector should be carried out periodically to optimize light output. Cleaning frequency depends on the environment in which the fixture operates (I.e. smoke, fog residue, dust, dew). In heavy club use we recommend cleaning on a monthly basis. Periodic cleaning will ensure longevity and crisp output.

- Unplug the product from power.
- Wait until the product is cold.
- Use a soft damp cloth to wipe down the outside projector casing.
- Use compressed air and a brush to wipe down the cooling vents and fan grill(s).
- Clean the glass panel (laser aperture) with glass cleaner and a soft cloth when dirty.
- Gently polish the glass surface until it is free of haze and lint.
- Always be sure to dry all parts completely before plugging the unit back in.

### SERVICE

**There are no user serviceable parts inside this unit. Do not attempt any repairs yourself; doing so will void your manufacturer's warranty. In the unlikely event your unit may require service, please contact us directly or your local distributor, who will help you with a repair or replacement. We will not accept any liability for any resulting damages caused by the non-observance of this manual or any unauthorized modification to this unit.**

